

Heavy Industrial-Duty Trolley Operator For Standard-Lift Sectional Doors

COMMERCIAL DOOR OPERATOR

MODEL
GT

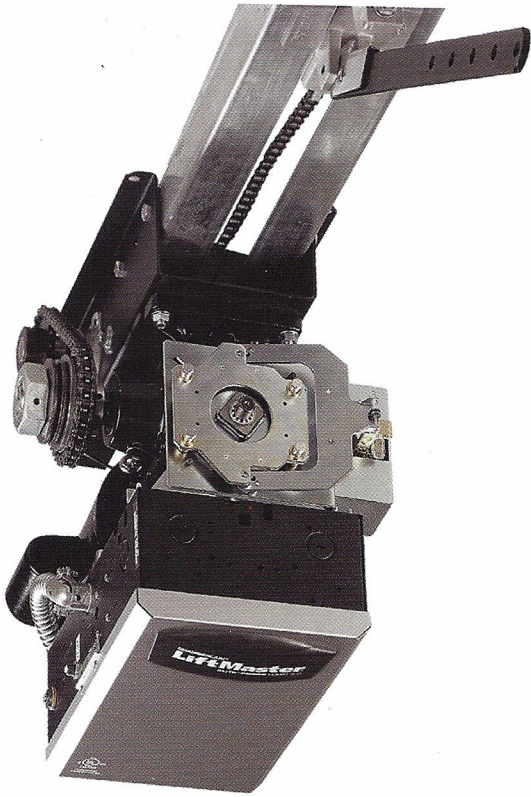

Logic 3.0 Technology
Elite Series™ Commercial Door Operators are engineered, manufactured and tested to provide reliable service to meet the toughest commercial applications.

Added Value

- Built-in 3-channel, 315MHz radio receiver accepts up to 23 Security+® or unlimited DIP switch remote controls.
- All LiftMaster® 3-button remotes can be programmed for open/close/stop operation.
- Maintenance Alert System™ lets you establish a routine maintenance schedule based on the number of cycles and/or calendar date. Includes self-diagnostic system for easy troubleshooting.
- Timer-to-close may be set to close in 5-second or 1-minute increments.
- Thermal motor overload can be reset from the 3-button control station.
- Built-in programmable mid-stop.
- Built-in programmable maximum run timer.

Reliability

- Switchless motor eliminates stuck start switch and motor malfunctions on single-phase operators.
- All high-voltage connections have been removed from the board for safer installation and improved reliability.
- 1-1/2 second delay-on-reverse helps prevent door and operator wear.

Programming Simplicity

- Selector dial replaces DIP switches for selecting wiring types and programming, including failsafe and non-failsafe wiring.
- Diagnostic LEDs speed installation and troubleshooting.
- Motor direction jumper lets you change motor direction by simply moving a jumper.

- Continuous-duty high-starting torque motor
- Quiet-gliding rail spacers
- Quick-mount swivel header bracket
- Removable hinged electrical box cover
- 115V, 208/230V, 460V, 575V, 24V NEC Class 2 Circuit with 40VA transformer

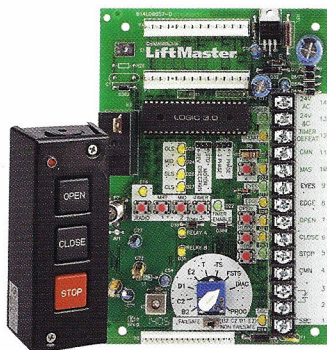

Includes the Logic 3.0 board and the exclusive Maintenance Alert System™

CHAMBERLAIN®

LiftMaster
ELITE SERIES™ LOGIC 3.0

GT

COMMERCIAL DOOR OPERATOR

MAXIMUM DOOR AREA (SQ. FT.)

STANDARD SECTIONAL	HORSEPOWER	24 GA./22 GA. STEEL	20 GA. STEEL	16 GA. STEEL		
		FIBERGLASS	ALUMINUM DOORS	WOOD DOORS		
			24 GA. STEEL INSULATED	20 GA. STEEL INSULATED	16 GA. STEEL INSULATED	
	1/2	400	350	320	250	200
	3/4	560	500	450	325	250
	1	625	575	500	400	300
	1-1/2		625	550	475	380

NOTE: On steel insulated doors, a 24-gauge back panel is assumed. If a heavier back panel is supplied, use the next higher HP rating.

Standard Features

- Motor**
 Continuous-duty high-starting torque motor with instant reverse and overload protection. Available in 1/2, 3/4, 1 and 1-1/2 HP; single- or three-phase. Capacitor start on single-phase. Removable without affecting limit switch settings.
- Quick-Mount Header Bracket**
 Includes quick-mount header bracket which provides fast, swing-up installation.
- Emergency Disconnect**
 Spring-loaded disconnect for emergency manual operation.
- Wiring Type(L3)**
 C2 (factory default), B2, D1 and E2 wiring types are available. Failsafe (T, TS and FSTS) wiring can be selected with the addition of a CPS-L, CPS-LN4 or failsafe edge and CPS3 card.
- Drive Reduction**
 10:1 first stage using heavy-duty gears running in oil bath; cast iron housing; #41 chain second stage; #41 chain on trolley.
- Brake**
 Heavy-duty solenoid-actuated brake.
- Bearings**
 Sealed roller bearings in gear reducer. Flange-mount industrial ball bearings on drive shaft.
- Clutch**
 Heavy-duty torque limiter helps protect against major damage to door and operator should the door meet an obstruction.
- Push Button Station**
 3-button station for open/close/stop functions is standard for all operators. Controls with 1, 2 and 3 buttons are available.
- Radio Receiver & External Radio Control Terminal**
 315MHz radio receiver included as standard on Logic 3.0. Accepts up to 23 Security+® remote controls or unlimited DIP switch remotes. External terminals provide quick, convenient connections for retrofitting or adding radio controls on logic or mechanical operators.
- Construction**
 NEMA 1 type electrical box, heavy-duty 11-gauge steel frame with durable powdercoat finish, all reduction sprockets drilled and pinned to shafts.
- Rail Assembly**
 High-strength dual L-rail track with exclusive nylon quiet-gliding chain guides on rail spacers for quiet, smooth operation. Includes heavy-duty wall-mount brackets for rail and operator.

Value Added Standard Features

- Timer-to-Close**
 Automatically closes the door – programmable in 5-second or 1-minute increments. Part of the CPS-L, CPS and CPS-LN4 photo-eye packages or in the Logic 3.0 plug-in card package.

- Maximum Run Timer**
 Signals door to reverse or stop if closing time exceeds maximum by more than 10 seconds.
- Mid-Stop**
 Stops door at programmable mid-stop during open travel.
- Delay-on-Reverse Circuit**
 A 1.5 second delay-on-reverse circuit to prevent premature door and operator wear.

Control Accessories and Options

- CPS® Commercial Protector System®:**
CPS(M), CPS-N4(M), CPS-L(L3), CPS-LN4(L3) (recommended)
 "Non-contact" photo safety sensor designed to sense an obstruction and signal the door operator to reverse to open.
- Sensing Edge (recommended)**
 Senses an obstruction and signals door operator to stop or reverse upon contact. An electric or pneumatic sensing device can be added to bottom edge of door. Requires D1, C2 or B2 wiring.
- Manual Hoist Modification**
 Allows easy emergency manual operation using a hoist mechanism without the need to disconnect and reconnect the trolley assembly.
- Treadle**
 Signals door operator to open and/or close when vehicle depresses treadle.
- Key Switch**
 Designed to restrict operation of door to authorized personnel only. Various types available.
- Transmitters**
 1- and 3-button transmitters available for Logic 3.0. 3-button transmitter can be programmed for open/close/stop functionality. Radio receiver and transmitters available for mechanical operators.

Available Plug-in Options for the Logic 3.0 Control Board (L3)

- Auxiliary Contact Board**
 Used to operate security, warning, heating or other 5V to 240V devices. Features both normally open and closed contacts that actuate in conjunction with limit switches.
- Red/Green Warning Light**
 Provides safety warning prior to close (when using timer-to-close feature).
- CPS3 Option**
 Enables the addition of a second set of photo-eyes or 2- or 4-wire, self-monitoring edge.

Available Mechanical Reversing Contactor Circuit (M)

Industrial linear contactor provides significantly longer control runs than conventional contactors. Circuit provides easy selection between C2 and B2 wiring with the movement of a single wire.

Technical Information

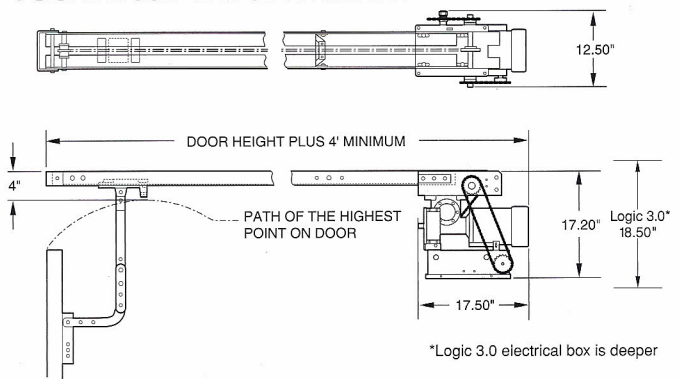

CHAMBERLAIN®

LiftMaster®

THE CHAMBERLAIN GROUP, INC.
 845 Larch Avenue • Elmhurst, IL 60126
www.liftmaster.com • <http://specs.chamberlain.com/architectscorner>



Chamberlain reserves the right to make design or specification changes without notice.
 ©2008 The Chamberlain Group, Inc. Printed in U.S.A. 6/08 LMCD30GT